

P/N# 25109
Sway Bar End Links
Installation Instructions



Thank you for your purchase of this Hotchkis Performance product. Your End Link set was designed with the performance and durability you've come to expect from Hotchkis Performance.

Note: Please read the entire installation instructions before starting. Having the right tools will ensure a smooth install process.

FRONT END LINK INSTALLATION

1. Raise the front end of the vehicle. Remove the front wheels.
2. Disconnect the OE end link from the sway bar ends. Retain the nut for reinstallation.



3. Disconnect the OE end link from the front struts. Retain the nut for reinstallation.



4. As a default setting, set the length of the Hotchkis links to the same length as the OE links.
5. Assemble the links as shown in the diagram. (Use the longer bolts for the front)

MISALIGNMENT SPACERS

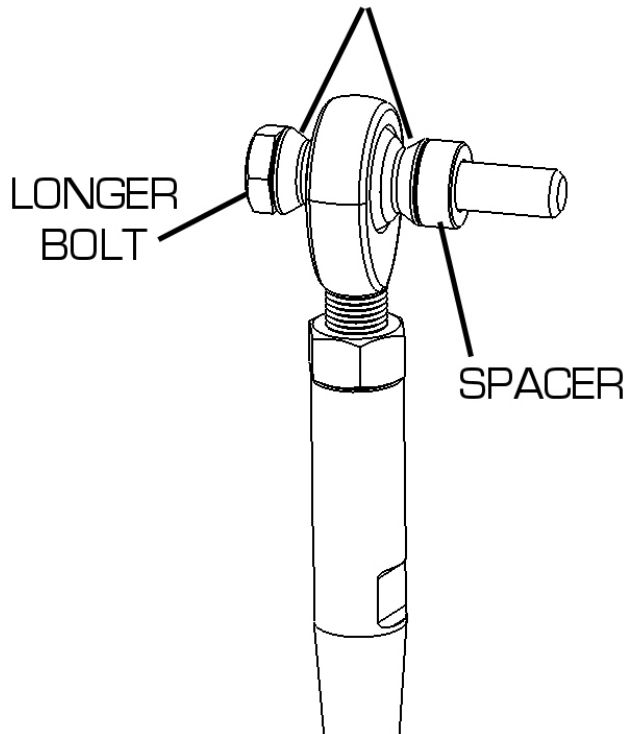

6. Reinstall the Hotchkis end links onto the vehicle in the same manner as removal. Reuse the OE nuts.
7. Clock the rod ends (heim joints) so that there is proper articulation throughout the entire steering travel. You should be able to turn the steering wheel left or right (lock to lock) and the rod ends should not bind. Once the rod ends are properly clocked, tighten the jam nuts on each end.

REAR END LINK INSTALLATION

1. Raise the rear end of the vehicle to access the underside. You do not need to remove the wheels. If you have drive-on floor ramps the installation will be easier.
2. Disconnect the OE end link from the sway bar ends. Retain the nut for reinstallation.



3. Disconnect the OE end link from the front struts. Retain the nut for reinstallation.



4. As a default setting, set the length of the Hotchkis links to the same length as the OE links. Tighten the jam nuts once the length is set.

5. Assemble the links as shown in the diagram. (Use the shorter bolts for the rear)

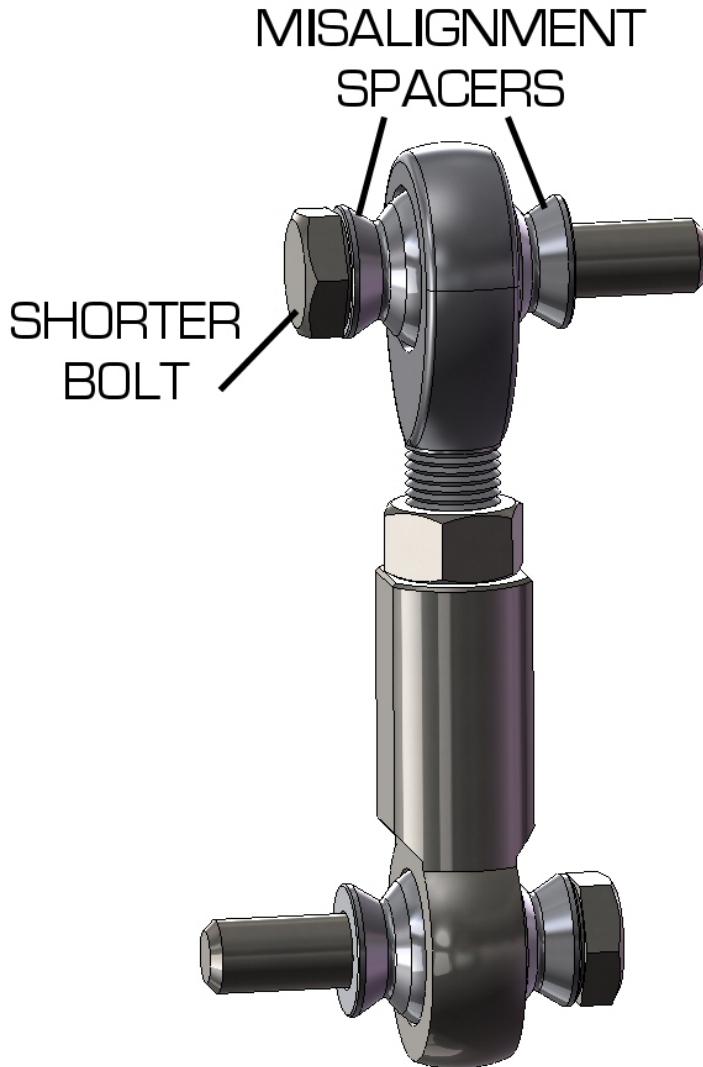

6. Reinstall the Hotchkis end links onto the vehicle in the same manner as removal. Reuse the OE nuts.