

***Rear Thrust Shim Kit 3003
67-76 A-Body, 66-69 B-Body
70-74 E-Body***

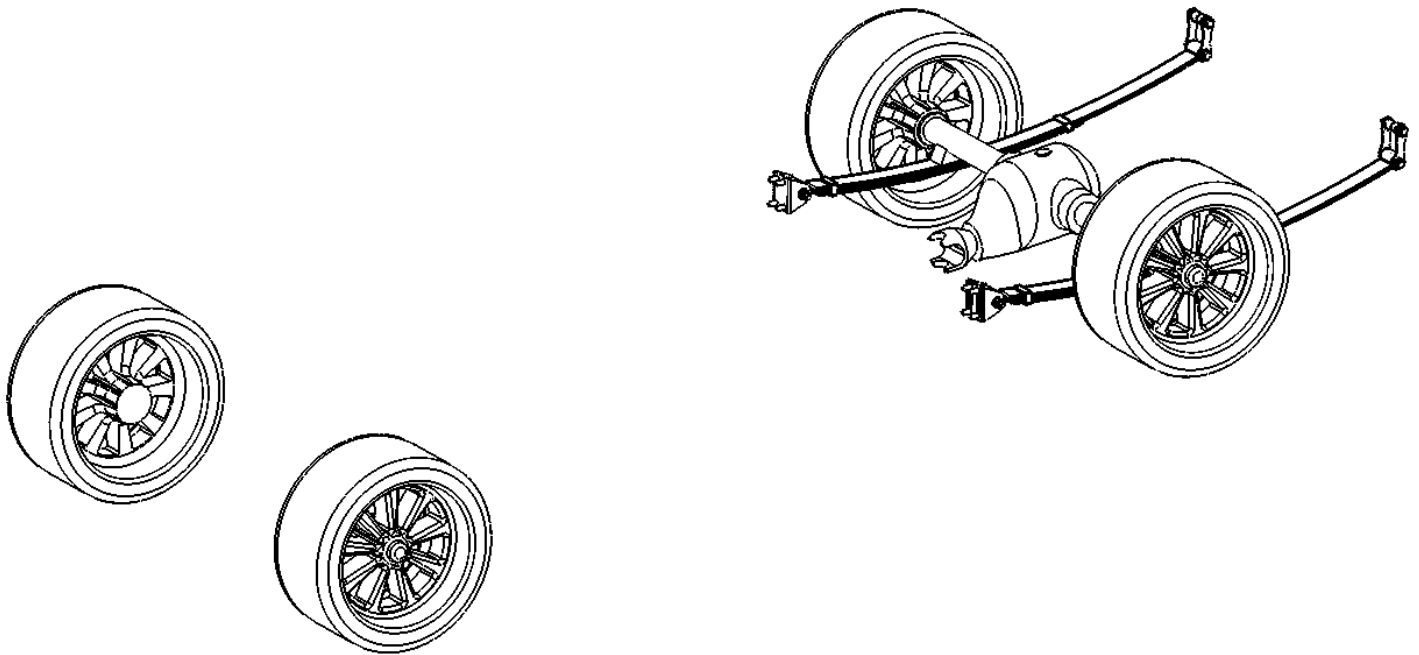

*Thank you for your purchase from our new line of Mopar parts.
Please call us at 877 - 4NO - ROLL if you have any questions
regarding the service or installation of your Hotchkis Performance products.*

**IMPORTANT: PLEASE READ THE ENTIRE INSTRUCTION MANUAL BEFORE
STARTING THIS INSTALLATION.**

1. Measure Alignment

The vehicle will need to be measured to determine whether or not the thrust angle requires adjustment. It is best to have this performed by a 4-wheel wheel alignment professional. Thrust angle is a common measurement observed in most alignment shops. If your vehicle requires thrust adjustment, then please proceed to the following steps using the Hotchkis Thrust Shim Kit.

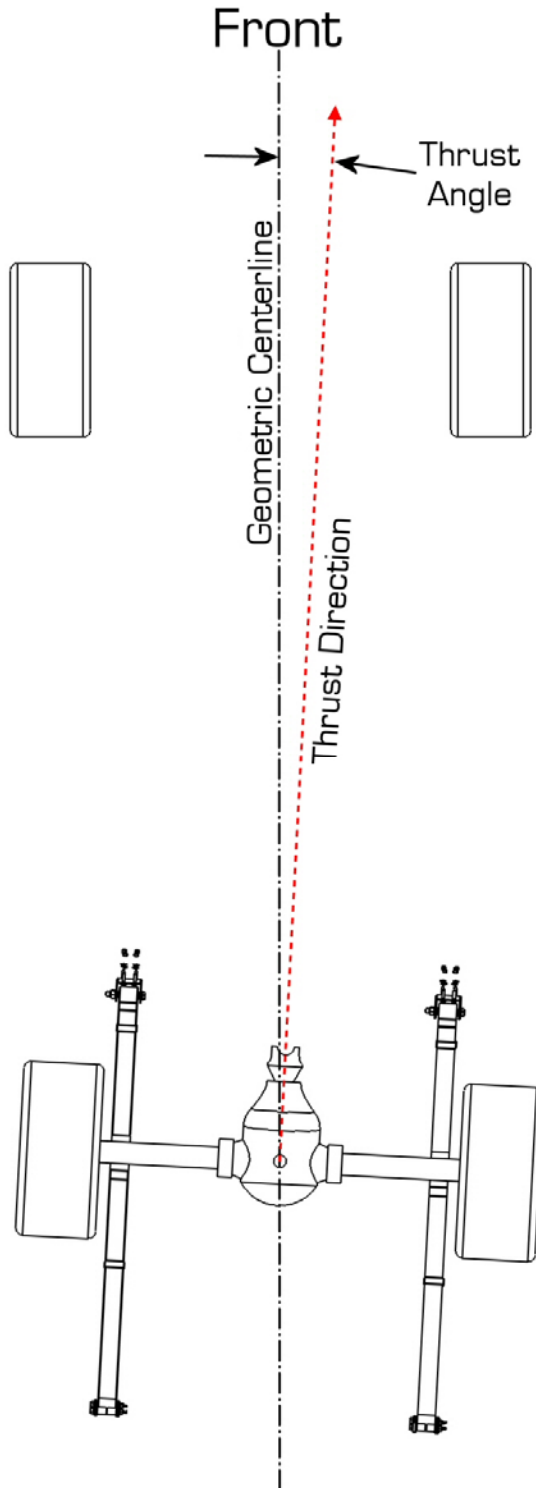

Terms:

Geometric Centerline: When observing the vehicle in plan view, this is an imaginary line that runs through the center of the front wheels and rear wheels

Thrust Direction: When observing the vehicle in plan view, the thrust direction follows an imaginary line that runs through the center of the rear wheels and points in the direction the rear wheels propel the vehicle. In live axle vehicles, thrust is typically parallel with the direction of the rear wheels.

Thrust Angle: The angular difference between the Geometric Centerline and the Thrust Direction. The thrust angle is positive when it points to the right and negative when pointed to the left. The goal is to have this angle to be zero.

2. *Raise the Vehicle*

Raise the vehicle and safely secure it on jack stands. Make sure to support the rear of the vehicle on the chassis rather than the differential.

3. *Support the Differential*

Place a jack underneath the rear differential pumpkin and apply jacking force until the weight of the differential is relieved. This will allow you to disconnect the front leaf spring mount without fighting any unwanted preloads.

4. *Install the Shims*

Begin unbolting the 4 nuts that secure the front leaf spring mount to the chassis on the side that requires shimming. Once mount is somewhat detached from the chassis, you can slide in the amount of shims you require. The kit comes with 6 shims @ 1/32" thickness.

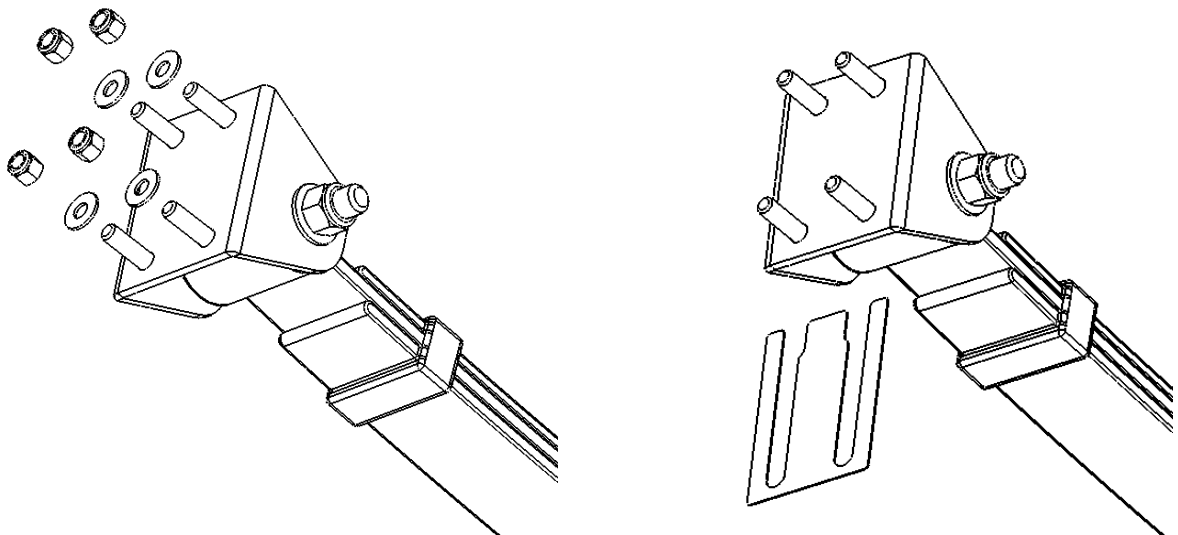

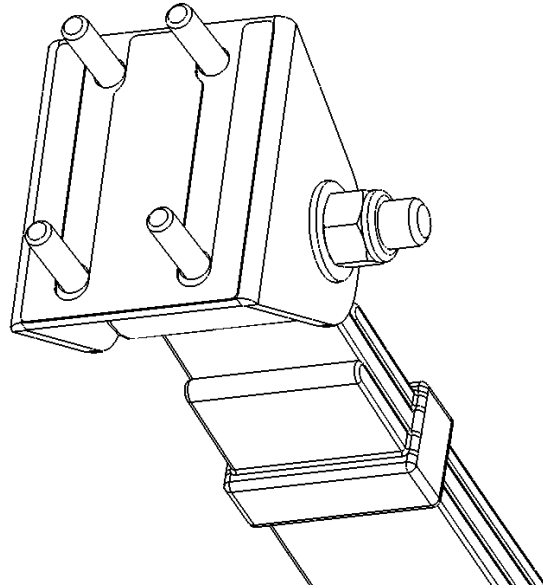

5. Reinstall Leaf Spring Mount

Reinstall the leaf spring mount in the same manner as removal.

6. Recheck Thrust Angle

Lower the vehicle back to ride height and recheck the thrust angle. Repeat this process of adding or removing shims until you have zero thrust angle.

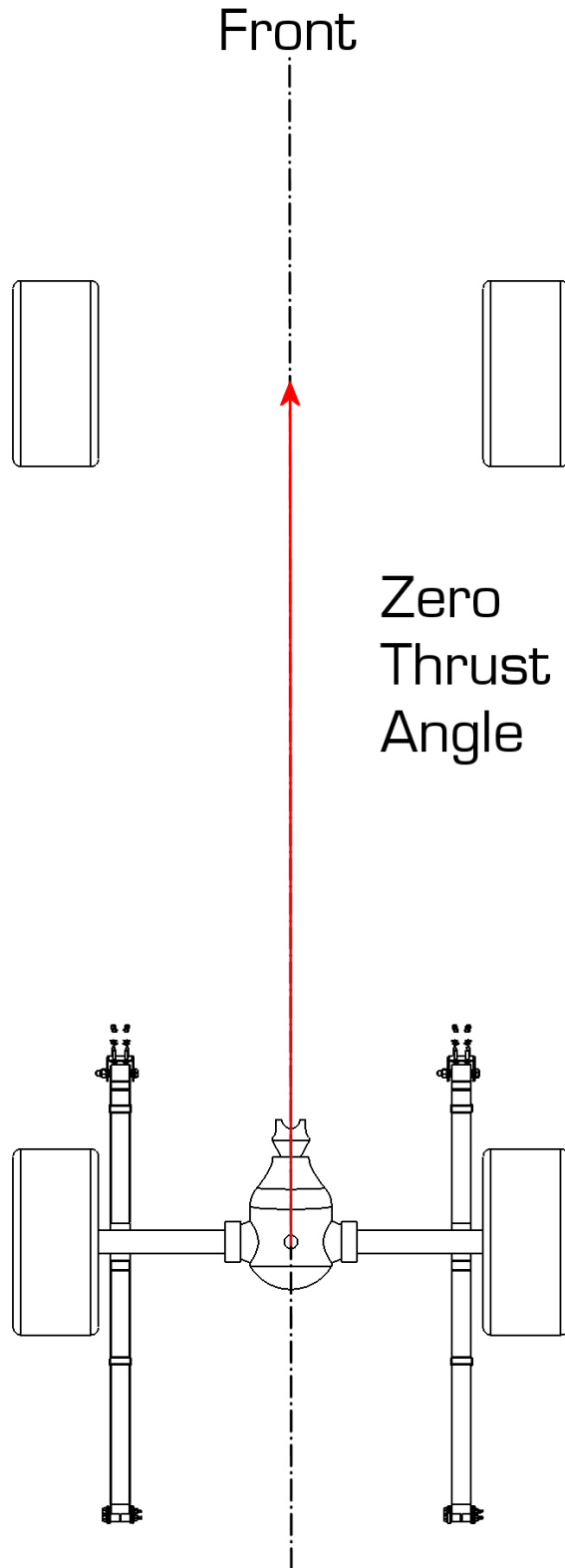

Hotchkis Performance LLC Return Policy & Limited Warranty

Effective January 1, 2009 all Hotchkis products must be registered to qualify for warranty at www.hotchkis.net or via the mail-in warranty card, included with the product, within 30 days of the original purchase date.

Return Policy

We want you to be completely satisfied with your Hotchkis Performance product. For products, presenting signs of shipping damage please contact the freight carrier immediately. All our products are guaranteed to be free from manufacturer's defects. If your order arrives with a manufacture defect, please contact our Customer Service Department at (562) 907-7757. You will be assigned a Returned Goods Authorization Number (RGA). The package you return must show the RGA on the outside of the package, include the original invoice and be shipped prepaid to our facility. The product has to be unused and in its original packaging materials. Exchanges or refunds made after 30 days will be subject to a 20% restocking charge. **If you purchased your Hotchkis Performance product from an authorized dealer, you are still covered by this return policy. All returns however, should be made to your dealer, not to Hotchkis Performance directly.**

Limited Warranty

Hotchkis Performance offers a Limited Warranty against defects in materials and workmanship of its products. This Warranty only applies to the original retail purchaser who retains ownership of the vehicle on which the product was originally installed. If the product is determined to be defective, Hotchkis Performance will repair, replace or refund the purchase price of the defective product at Hotchkis Performance's sole discretion, which shall fully satisfy and discharge any and all warranty claims. Any repaired or replaced product will be returned to the sender excluding the cost of freight. **Products must be registered to qualify for warranty at www.hotchkis.net or via the mail-in warranty card, included with the product, within 30 days of the original purchase date.**

Exclusions from Warranty

Items offered but not manufactured by Hotchkis Performance are warranted according to the manufacturer's terms and are not covered by this limited warranty. Hotchkis Performance shall not be responsible for any labor, removal, installation, re-installation or maintenance costs. This warranty does not cover the cosmetic finish or plating of any product or any normal wear and tear to any product including, but not limited to bushings, brackets, end-links, hardware, steering components, shocks or springs. In addition, this warranty does not apply to any products that have been:

- Improperly installed or installed by someone other than a qualified, licensed auto mechanic experienced in the installation and removal of suspension products;
- Improperly serviced, misused, or modified, altered or subjected to abuse, negligence, accident or collision;
- Installed in any vehicle that has been modified;
- Installed on any vehicle that has carried loads in excess of automobile manufacturer suggested weight limits; or
- Installed on any vehicle that has been subject to abnormal or excessive use, including rallying, racing, or racing-type activities or off-road use.

Limitation of Warranty

This limited warranty is the entire and only warranty for the products and may not be modified or supplemented by any other person or company in any form. Any description of the products, by anyone, is for the sole purpose of identifying them and is not part of the basis of the bargain, and does not constitute a warranty that the products will conform to that description. The statements of any salesperson do not constitute part of this limited warranty and cannot be relied upon as a warranty.

THERE ARE NO WARRANTIES, EXPRESSED OR IMPLIED, INCLUDING ANY IMPLIED WARRANTIES OF MERCHANTABILITY OR FITNESS FOR A PARTICULAR PURPOSE, WHICH EXTEND BEYOND THE DESCRIPTION ON THE FACE HEREOF. ANY IMPLIED WARRANTIES ARE DISCLAIMED TO THE FULLEST EXTENT PERMITTED BY LAW. THIS WARRANTY DOES NOT COVER CONSEQUENTIAL DAMAGES, LOSS OF TIME OR REVENUES, INCONVENIENCE, LOSS

OF USE OF THE VEHICLE, DAMAGE TO THE VEHICLE OR COMPONENTS OF THE VEHICLE, ANY OTHER TYPE OF CONSEQUENTIAL DAMAGES, OR OTHER INCIDENTAL OR INDIRECT DAMAGES. HOTCHKIS' MAXIMUM LIABILITY UNDER THIS WARRANTY SHALL IN NO EVENT EXCEED THE PURCHASE PRICE OF THE PRODUCT. Some states do not allow limitations on how long an implied warranty lasts or the exclusion or limitation of incidental or consequential damages and in such states the above limitations or exclusions may not apply. This limited warranty gives the purchaser specific legal rights and the purchaser may have other rights that may vary from state to state.

Technical Information

Hotchkis Performance makes every effort to ensure that you are provided with the most accurate and up-to-date technical information. However, all technical information is approximate and may vary upon application. Additional suspension components may be needed in some applications, depending upon the make, model, engine and chassis of the vehicle. Hotchkis Performance is not responsible for any consequences resulting from manufacturer's technical mid-year changes. Hotchkis Performance products should only be installed by a qualified, licensed auto mechanic experienced in the installation of such products.

Warranty Claim Procedure:

The answer to ALL the following questions should be YES before making a warranty claim:

- Did you register the product at www.hotchkis.net or via the mail-in warranty card within 30 days of purchase?
- Is the product appropriate to your application?
- Did you carefully and thoroughly read the instructions provided along with the product?
- Do you have the original invoice or sales receipt?
- Are you the original purchaser?
- Was the product properly installed by a qualified, licensed auto mechanic?
- Has the product been installed on the original vehicle on which it was installed at all times?
- Is the product unmodified and clean?
- Is the reason for return a legitimate product defect?

If the answer to all these questions is YES, please contact our Customer Service Department at (562) 907-7757. You will be given a Returned Goods Authorization Number (RGA) valid for 60 days. You will also be asked to ship the product prepaid to our facility. All shipments MUST be (i) prepaid, (ii) include the original invoice or sales receipt, (iii) show the RGA on the outside of the package and (iv) include your name, address, make and model of the vehicle, and a brief description of the claimed defect, including the circumstances under which the defect occurred. If the warranty claim is deemed valid then Hotchkis will estimate shipping costs to return the repaired or replacement part and contact you for payment. Hotchkis's Limited warranty requires that any repaired or replaced product will be returned to the sender excluding the cost of freight. Warranty related inquires should be sent to the following address:

**HOTCHKIS PERFORMANCE, LLC
C/O CUSTOMER SERVICE
12035 BURKE ST. SUITE 13
SANTA FE SPRINGS, CA 90670**

Hotchkis Performance will not accept product returns without the RGA number, receipt and the information described above. C.O.D. or collect shipments will be refused. Once the returns are received at Hotchkis Performance, we will evaluate the products, verify the sales receipt, and investigate the warranty claim. Any repaired or replaced product will be returned to the sender.

Effective January 1, 2009. This return policy and limited warranty supersedes all previous policy and warranty statements. Policies and warranties are subject to change without notice. Hotchkis Performance is not responsible for printing errors.